

Technology Offer

Acidic DNA-Ligase

Reference Number
TO 02-00096a

The Challenge

DNA-ligases catalyze the formation of a phosphodiester bond between juxtaposed 5'-phosphate and 3'-hydroxyl termini in duplex DNA or RNA with blunt or cohesive-end termini. DNA-ligases are used in all sectors of genetic engineering for joining double-stranded DNA with cohesive or blunt termini, for joining of oligonucleotide linkers or adaptors to blunt-ended DNA, for repairing nicks in duplex DNA, RNA or DNA-RNA hybrids, for ligase-mediated RNA detection and for site-directed mutagenesis. All thus far known DNA-ligases need Mg^{2+} or Mn^{2+} ions as essential co-factors for activity and have a neutral pH-optimum at about pH 7. For certain specific applications Mg^{2+} or Mn^{2+} ions in the ligation buffer might be disadvantages. On the other hand enzyme activity clearly below pH 7 could be favourable in some cases.

The Technology

We offer a novel DNA-ligase obtained from the acidophilic ferrous-iron-oxidizing archaeobacterium *Ferroplasma acidiphilum*,. The enzyme is active and stable at extremely low pH between pH 2 and 3 and uses iron Fe^{2+} as co-factor for activity instead of Mg^{2+} or Mn^{2+} ions, which are usually co-factors of DNA-ligases. The acidic pH-optimum of this special ligase offers the opportunity to develop a one-tube PCR/ligation protocol by taking advantage of

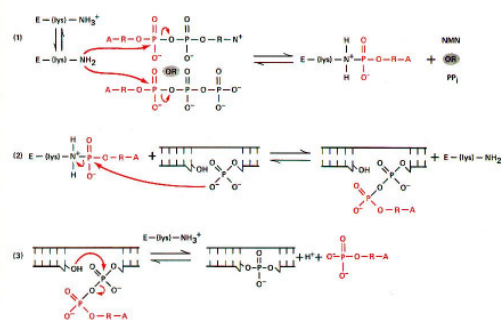

Source: Biochem 201 site at Stanford University

the possibility to switching on and off enzyme activity by directed pH-shifts.

Commercial Opportunity

The offered DNA-ligase has some very special properties making this enzyme useful for specific experimental approaches regarding genetic engineering and is therefore applicable for the development of specialised research kits. Advantages are:

- low pH-optimum clearly below 4
- high stability at low pH
- high specific activity
- easy production by fermentation
- low costs of production

Patent situation

European patent application was filed in March 2005 (EP 05 101 628). The international application has been published WO2006/094943.

Contact:

Sabina Heim, Ph.D.
Technology Manager
Ascension GmbH

T: +49 (0)531-6181-2090
F: +49 (0)531-6181-2098
E: heim@ascension.de



Berlin
Braunschweig
Hamburg
Munich

Ascension GmbH
Herzogstrasse 64
80803 Munich
Germany

Intellectual Property
Asset Management

An Enterprise of the
Foundation for the
Promotion of Life Sciences